

Technical data sheet

Product features



Cooking range glass ceramic drop-in electric 2x drop-in plate 400 V

Model	SAP Code	00007446
--------------	-----------------	----------



- Device type: Electric unit
- Power consumption of the zone 1 [kW]: 2,5
- Power consumption of the zone 2 [kW]: 2,5
- Protection of controls: IPX5
- Material: Stainless steel

SAP Code	00007446	Loading	400 V / 3N - 50 Hz
Net Width [mm]	400	Number of zones	2
Net Depth [mm]	600	Power consumption of the zone 1 [kW]	2,5
Net Height [mm]	50	Power consumption of the zone 2 [kW]	2,5
Net Weight [kg]	10.00	Ceramic glass dimensions [mm x mm]	350 x 570
Power electric [kW]	5.000		

Technical data sheet

Technical drawing



Cooking range glass ceramic drop-in electric 2x drop-in plate 400 V

Model

SAP Code

00007446

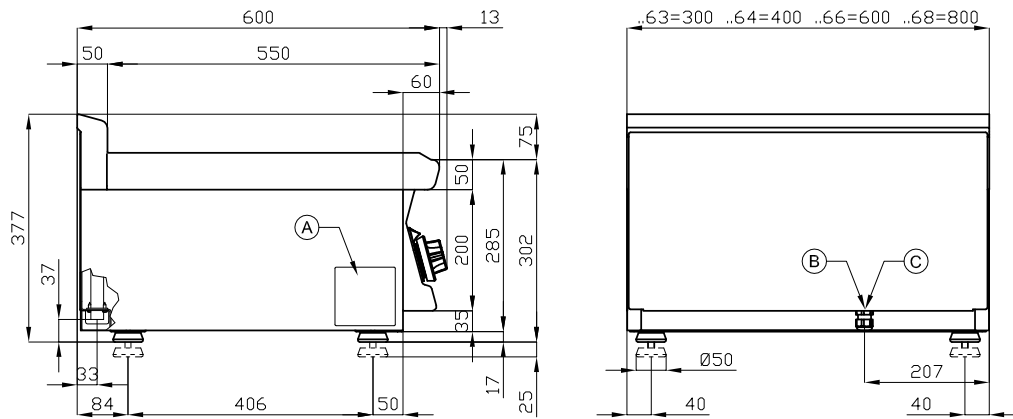

A	Data plate		B	Electrical connection	
---	------------	--	---	-----------------------	--

Technical data sheet

Product benefits



Cooking range glass ceramic drop-in electric 2x drop-in plate 400 V

Model

SAP Code

00007446

1

Glass ceramic surface

- quick warm-up
- uniform heating and residual heat indicator
 - saving time in food preparation
 - no reheating and long cooking times
 - material does not rust

2

Internal thermostatic plate protection

- longer service life of the plates
 - no overheating of the plates and no cracking

3

Degree of protection of the control elements IPX5

- maintenance-free system
- resistance to splash water
- long life
 - savings on service interventions
 - easy cleaning and maintenance of equipment

4

All-stainless design

- the material does not cut
- wear resistance of the material
- long life
 - savings on service interventions
 - easy cleaning and maintenance of equipment

5

Hygienic moldings of the top plate

- absence of sharp corners and edges (potential places where dirt could stick)
- smooth transitions
 - easy quick cleaning

6

Variability

- the possibility of attaching to a fixed plate as part of a monoblock
- the possibility of creating one module
- long life
 - cost saving
 - space saving
 - long service life

Technical data sheet

Technical parameters



Cooking range glass ceramic drop-in electric 2x drop-in plate 400 V

Model

SAP Code

00007446

1. SAP Code:

00007446

2. Net Width [mm]:

400

3. Net Depth [mm]:

600

4. Net Height [mm]:

50

5. Net Weight [kg]:

10.00

6. Gross Width [mm]:

430

7. Gross depth [mm]:

630

8. Gross Height [mm]:

470

9. Gross Weight [kg]:

12.00

10. Device type:

Electric unit

11. Construction type of device:

Drop-in

12. Power electric [kW]:

5.000

13. Loading:

400 V / 3N - 50 Hz

14. Protection of controls:

IPX5

15. Material:

Stainless steel

16. Worktop type:

Molded - comfortable cleaning maintenance

17. Worktop material:

AISI 304

18. Worktop Thickness [mm]:

2.00

19. Number of zones:

2

20. Power consumption of the zone 1 [kW]:

2,5

21. Power consumption of the zone 2 [kW]:

2,5

22. Number of power control stages:

6

23. Service accessibility:

From the front by removing the front panel and waste fluid containers

24. Safety element:

internal thermostatic protection of the hotplate against overheating

25. Safety thermostat:

Yes

26. Number of burners/hot plates:

2

Technical data sheet

Technical parameters



Cooking range glass ceramic drop-in electric 2x drop-in plate 400 V

Model	SAP Code	00007446
--------------	-----------------	----------

27. Type of electric cooking zones:

Glass ceramic

28. Ceramic glass dimensions [mm x mm]:

350 x 570